



2022 SAUDI BAJA - HAIL
RALLY GUIDE

RALLY GUIDE

SAUDI BAJA - HAIL
ROUND OF THE FIA WORLD CUP FORCROSS-COUNTRY BAJA 2022

AUTO

10 - 12 NOVEMBER 2022

ENGLISH VERSION

2022

TABLE OF CONTENTS

1	WELCOME AND INTRODUCTION	4
1.1	WELCOME TO SAUDI BAJA HAIL 2022	4
1.2	ROUTE TERRAIN ON SELECTIVE SECTIONS	5
1.3	AVERAGE ALTITUDE	5
2	CONTACT DETAILS	6
2.1	ORGANIZER'S NAME, ADDRESS AND CONTACT DETAILS	6
2.2	KEY OFFICIALS	6
2.3	RALLY HQ CONTACT DETAILS	6
2.4	RALLY OFFICE OPENING HOURS	6
2.5	MEDIA CONTACT DETAILS	6
3	PROGRAMME	7
4	ENTRY DETAILS	8
4.1	FIA CHAMPIONSHIPS AND TITLES FOR WHICH THE BAJA COUNTS	8
4.2	ENTRY FEES/ENTRY FEE PACKAGES	8
5	SERVICE PARK	9
5.1	NUMBER AND LOCATION	9
5.2	ACCESS TIMES FOR SERVICE VEHICLES	9
5.3	ASSISTANCE BETWEEN FIA COMPETITORS STILL IN THE RACE IS PERMITTED IN ALL THE BAJA	9
5.4	FUEL/REFUEL	9
5.5	GENERAL REGULATIONS FOR SERVICE	10
5.6	INFRACTIONS OF THE SERVICE AND REFUELLING RULES - PENALTIES	10
5.7	ENVIRONMENTAL MAT	10
5.8	GARBAGE BINS	10
6	TWO-WAY RADIO	10
7	FUEL/ TYRES	10
7.1	FUEL	10
7.2	TYRES	10
8	IMPORT OF VEHICLES AND SPARE PARTS	11
9	HOSPITALITY ARRANGEMENTS	11
9.1	HOSPITALITY AND TOURISM	11
10	HOTEL/ ACCOMMODATION RESERVATION	12
10.1	ACCOMMODATION RESERVATIONS	12
11	SHAKEDOWN	12
12	START PROCEDURE	13
12.1	SAUDI BAJA CEREMONIAL START PROCEDURE & ORDER	13
12.2	LEG 1 / SECTION 1 – START, THURSDAY NOVEMBER 10 TH , 2022, PROCEDURE	13
12.3	LEG 1 / SECTION 2 – START, FRIDAY NOVEMBER 11 TH , 2022, PROCEDURE	13
12.4	LEG 2 / SECTION 3 – START, SATURDAY NOVEMBER 12 TH , 2022, PROCEDURE	13
13	FINISH PROCEDURE	14

14	PR ACTIVITIES	14
15	MEDIA	15
	15.1 CONTACT DETAILS OF THE MEDIA SERVICES BEFORE AND DURING THE RALLY	15
	15.2 MEDIA ACCREDITATION PROCEDURE	15
	15.3 MEDIA SAFETY	15
16	PASSES AND PLATES	16
	16.1 PASSES	16
	16.2 PARKING SPOTS FOR OFFICIALS CARS	16
	16.3 PLATES / STICKERS FOR OFFICIALS CARS	17
17	MEDICAL AND SAFETY SERVICES	18
	17.1 EMERGENCY TELEPHONE NUMBERS	18
	17.2 LIST OF SOME HOSPITALS IN THE AREA, ADDRESSES & TELEPHONE NUMBERS:	18
	17.3 LIST OF SOME PHARMACIES IN THE AREA, ADDRESSES & TELEPHONE NUMBERS:	18
18	USEFUL FACTS AND SERVICES	19
	18.1 CLIMATE	19
	18.2 TIME ZONE	19
	18.3 CURRENCY.....	19
	18.4 HIRE CAR COMPANIES	19
	18.5 AIRPORTS AND AIRLINE COMPANIES.....	19
	18.6 COPY SERVICE	19
	18.7 MOBILE PHONE (RENTAL AND SERVICE)	19
	18.8 SECURITY COMPANIES	19
	18.9 TAXIS.....	19
	18.10 SPEED LIMITS IN SAUDI ARABIA.....	20
19	APPENDIX 1 – ITINERARIES	21
20	APPENDIX 2 – MAPS	22
21	APPENDIX 3 – ROAD BOOKS	23
	21.1 FROM HAIL INTERNATIONAL AIRPORT TO MILLENNIUM HOTEL / RALLY HQ	23
	21.2 FROM MILLENNIUM HOTEL / RALLY HQ TO HAIL INTERNATIONAL AIRPORT	23
	21.3 ERTF LINK.....	23
	21.4 ROAD BOOKS	23
22	APPENDIX 4 – DRAWINGS AND LAYOUTS	29
	22.1 SCRUTINEERING VENUE LAYOUT.....	29
	22.2 PARC FERME LAYOUT.....	30
	22.3 RALLY HQ LAYOUT	31
	22.4 SERVICE PARK LAYOUT	32
23	APPENDIX 5 – SUMMARY OF PENALTIES	33
24	APPENDIX 6 – DIGITAL OFFICIAL NOTICE BOARD - SPORTITY	36
25	APPENDIX 7 – HOTEL AND TRANSPORTATION DISCOUNT	37

For Information Only

This Document Has No Regulatory Power

All Information is Correct at the Time of Publishing

Updates Can be found on Sportity App.

1 WELCOME AND INTRODUCTION

1.1 Welcome to Saudi Baja Hail 2022

The 2022 Saudi Baja – Hail, an official round of the FIA BAJAS WORLD CUP 2022, will take place in Hail, Saudi Arabia. From 10 to 12 November 2022.

The Saudi Baja Hail enters its third year on the FIA Cross Country World Cup calendar.

Located in northern Saudi Arabia, Hail was once a key part of the route taken by pilgrims for the Hajj by camel, and today is better known for its agriculture, in particular wheat and dairy products.

As-Samra Mountain offers an incredible view over the city, while the surrounding desert landscape offers the perfect terrain for rallying.

Motorsport also isn't new to the city with the Hail Rally first taking place in 2006, later becoming an FIA-sanctioned event in 2008, and has become a key location in the Kingdom hosting the Dakar Rally since 2020.

In fact, the Hail Rally has become an excellent tune-up event for competitors to prepare themselves and their vehicles for the challenge of the Dakar.

We look forward to seeing the teams, drivers and riders in Hail, Saudi Arabia this November.

Good Luck to All!

1.2 Route terrain on Selective Sections

Route type	Percentage	
Gravel/dirt tracks	10	%
Open desert	85	%
Dunes	5	%
[other surfaces]	0	%

Leg 1 Safety Type A,

Leg 2 Safety Type A,

1.3 Average Altitude

The average altitude recorded at least every 100 meters of the total distance of selective sections of the event as per the below Diagram.

Stage	Alt. (m) @ start	Average alt (m)	Lowest Alt (m)	Highest Alt (m)
SS 1A	937	933	896	958
SS 1B	844	926	844	988
SS 2	966	972	892	1148

Maximum slop

SS 1A 14.1%

SS 1B 7.9%

SS 2 11.7%

Average Slope:

SS 1A 3.0%

SS 1B 1.2%

SS 2 1.4%

2 CONTACT DETAILS

2.1 Organizer's name, address and contact details

Organizer:	Saudi Automobile & Motorcycle Federation
Organizer's representative:	Sattam AL HOZAMI
Street/P.O. Box:	4627 Al Baji - Al Sharafiyah Dist. 4627 – Unit 2
Post code/city:	RIYADH 12724 - 7265
Phone and fax:	Tel.: +966 011 880 4614 Mob.: +966 554255547
E-mail:	info@samf.gov.sa

2.2 Key Officials

Title	Name	Mobile	Email Address
Clerk of the Course - Auto	Khaled ZAKARIA	-	kzakaria@yahoo.com
Deputy Clerk of the Course	Mazen DAJANI	-	mazen@dajaniandco.jo
Deputy Clerk of the Course	Samer Hejazi		Hejazi_samer@hotmail.com
Secretary of the Rally	Ahmed YASIN	-	ayasin@samf.gov.sa
Media Relations Officer	Asma AL-HUMAID	-	aalhumaid@samf.gov.sa
Media Centre Officer	Asma AL-HUMAID	-	aalhumaid@samf.gov.sa
Press Officer – Arabic	Asma AL-HUMAID	-	aalhumaid@samf.gov.sa
Press Officer – English	Asma AL-HUMAID	-	aalhumaid@samf.gov.sa
Service Park Manager	Mansour EL JAWHAR	-	-
Chief Medical Officer	Dr Ahad AL SAUD	-	a.alsaud@samf.gov.sa
CRO	Abdul Aziz AL KAMEL	-	cro@samf.gov.sa

2.3 Rally HQ Contact Details

Millennium Hotel Hail	
Al Khotta Road, North Hail	
Telephone	+966 16 538 6111
E-mail	info@samf.gov.sa

2.4 Rally Office Opening Hours

Tuesday, November 8 th	10:00 – 17:00hrs
Wednesday, November 9 th	06:30 – 20:00hrs
Thursday, November 10 th	06:30 – 21:00hrs
Friday, November 11 th	06:30 – 21:00hrs
Saturday, November 12 th	06:30 – 19:00hrs

2.5 Media Contact Details

Media Centre Officers

Title	Name	Mobile	Email
Public relations	Asma AL-HUMAID	+966 54 505 4222	aalhumaid@samf.gov.sa
Brand Manager	Faisal ALDAHMAHSH	+966 55 444 6447	faldahmash@samf.gov.sa

3 PROGRAMME

DATE	TIME	EVENT	LOCATION
07 Oct 22 Friday	10:00	Entries open	Website
15 Oct 22 Saturday	10:00	Publishing of the Supplementary Regulations	Sportity/Website
29 Oct 22 Saturday	23:59	Closure date of entries/Co-Driver details submission	
30 Oct 22 Sunday	20:00	Issuing of Rally Guide	Sportity/Website
02 Nov 22 Wednesday	20:00	Publication date of entry list (upon FIA approval)	Sportity/Website
	20:00	Closing Date to order extra space in Service Park	
5 Nov 22 Saturday	14:00	Publication of Schedule for Admin. Checks and Scrutineering	Sportity/Website
08 Nov 22 Tuesday	10:00	Service Park Opens for logistics only	Baja H.Q. - Hail
	10:00 – 17:00	Opening Rally Office	Baja H.Q. - Hail
	10:00 – 17:00	Opening Media Centre	Baja H.Q. - Hail
	10:00 – 17:00	Opening Media Accreditation	Baja H.Q. - Hail
09 Nov 22 Wednesday	06:30	Service Park Opens	Baja H.Q. - Hail
	06:30 – 20:00	Opening Rally Office	Baja H.Q. - Hail
	06:30 – 20:00	Administrative Checks, as per Article 9.3 of the SR	Baja H.Q. - Hail
	06:30 – 20:00	Collection of material and documents	Baja H.Q. - Hail
	06:30 – 20:00	Collection of Baja safety tracking system	Baja H.Q. - Hail
	07:00 – 22:00	Scrutineering – Sealing & marking of components, Article 10.1 of the SR	Baja H.Q. - Hail
	09:00	Opening of media center/media accreditation	Baja H.Q. - Hail
	19:00	Pre-Baja Press Conference	Baja H.Q. - Hail
	20:00	Drivers' and team Briefing	Baja H.Q. - Hail
10 Nov 22 Thursday	06:30	Opening Rally Office	Baja H.Q. - Hail
	06:30 – 10:00	Re-Scrutineering – sealing & marking of components	Baja H.Q. - Hail
	08:00	Opening Media Centre	Baja H.Q. - Hail
	13:00 12:00	Publication of list of cars eligible start	Sportity/Website
	13:00 12:00	Publication of Start list for the Ceremonial Start	Sportity/Website
	13:00 12:00	Publication of Start list for the Qualifying Stage	Sportity/Website
	12:30 13:30 12:00 – 13:00	Pre - Ceremonial Start – Holding In	*Ceremonial Start Venue Maghawāt Park
	14:00 13:30	Issuing of Road Book for Qualifying Stage SS1A	*Ceremonial Start Venue Maghawāt Park
	14:00 13:30	Ceremonial Start	*Ceremonial Start Venue Maghawāt Park
	15:30 15:45	First Car starts Qualifying Stage Leg1/Section 1	*Ceremonial Start Venue Maghawāt Park
	19:30	Publication of provisional Classification of Qualifying Stage (QS)	Baja H.Q. - Hail
	20:00	Start Position Selection Leg 1 Section2 (QS 1st 10 positions)	Baja H.Q. – Hail
	21:00	Publication of Start List for Leg1/Section 2	Baja H.Q. – Hail
11 Nov 22 Friday	06:30	Opening Rally Office	Baja H.Q. – Hail
	06:30	Issue of Road Book Leg 1/Section 2	Service Park – H.Q. Hail
	07:00	Start of the Baja – Leg 1/Section 2	Service Park – H.Q. Hail
	08:00	Opening Media Centre	Baja H.Q. - Hail
	Approx. 14:50	Finish of Leg 1/Section 2 (estimated time of 1 st car)	Service Park – H.Q. Hail
	19:00	Publications of Provisional Classification for Leg1	Sportity/Website
	20:00	Publication of start list for leg 2/Section 3	Sportity/Website
12 Nov 22 Saturday	06:30	Re-Scrutineering	Service Park – H.Q. Hail
	06:30	Opening Rally Office	Baja H.Q. – Hail
	06:30	Issue of Road Book Leg 2/Section 3	Service Park – H.Q. Hail
	07:00	Start of the Baja – Leg 2/Section 3	Service Park – H.Q. Hail
	08:00	Opening Media Centre	Baja H.Q. - Hail
	Approx. 13:45	Finish of Leg 2/Section 3 (estimated time of 1 st car)	Service Park – H.Q. Hail
	Immediate after arrival to finish	Final Scrutineering (following the marshals' instructions)	
	17:30	Publication of Provisional Classification	Sportity/Website
	17:30	Post-Baja Press Conference	Baja H.Q. - Hail
	After the Stewards have declared the Classification final	Publication of Final Classification	Sportity/Website
	18:15 – 19:00	Pre Finish Ceremony – Holding Area	*Pre Finish Ceremony Maghawāt Park
19:30	Prize Giving Ceremony	*Finish Ceremony – Venue Maghawāt Park	

4 ENTRY DETAILS

4.1 FIA Championships and titles for which the Baja counts

FIA WORLD CUP FOR CROSS-COUNTRY BAJA'S
World Cup for Drivers
World Cup for Co-Drivers
World Cup for Teams
World Cup for T ₃ Drivers
World Cup for T ₄ Drivers
World Cup for T ₄ Teams

FIA MIDDLE EAST CUP FOR CROSS COUNTRY BAJA'S
Middle East Cup for Drivers
Middle East Cup for Co-Drivers
Middle East Cup for Teams
Middle East Cup for T ₃ Drivers
Middle East Cup for T ₄ Drivers
Middle East Cup for T ₄ Teams

4.2 Entry fees/entry fee packages

4.2.1 With organizers' optional advertising (see FIA CCRSR Article 20).

#	Included	Overseas Entries	Gulf Entries	Saudi Entries
1	Tracking & Navigation equipment rental (an additional deposit of €500 is required during documentation)	√	√	√
2	Tracking & Navigation installation kit	no	no	no
3	Insurance (third party)	√	√	√
4	Rally car plates kit (numbers, obligatory & optional advertising, etc.)	1	1	1
5	Baja Documents Kit (Road Books & Supplementary Regulations)	1	1	1
6	Set of wrist bands for crew x2, team manager x1, team members x4, and service x3 (armband)	1	1	1
7	Team car plate (Truck or Service or Auxiliary)	1	1	1
8	Team Manager car plate (minimum 2 race cars)	1	1	1
9	Merchandise (Driver & Co-Driver)	√	√	√
10	Service Area 15x10m	√	√	√
	Entry Fee in (€) with the Optional advertising	€ 4,000	€ 1,550	€ 1,100
	Entry Fee in (SAR) with the Optional advertising	SR 15,000	SR 5700	SR 4000

4.2.2 Fees mentioned includes the optional advertising, if a competitor does not accept the optional advertising the entry fee will be increased by 60%.

5 SERVICE PARK

5.1 Number and location

- There will be one Service Park for the duration of the Baja.
- The Service Park is located at Millennium Hotel – Hail.
- Service can be done only inside the Service Park.
- GPS location: 27°39'10.4"N 41°43'26.8"E

5.2 Access times for service vehicles

- The service park will open for logistics operations only as per Article 3 above, the service vehicles will be allowed to enter the service park on that date only to off-load and setup their service area.
- The service park will be fully operational as per Article 3 above.

5.3 Assistance between FIA competitors still in the race is permitted in all the Baja.

5.4 Fuel/Refuel.

- In the Service Park it is forbidden to refuel.
- Refueling is permitted only in the designated commercial fuel stations, or in the designated refuel zones. Solely for the purpose of assisting with the refueling procedure of their vehicle, two team members of each crew may access the Refueling Zone (other than inside a competitive part of a Selective Section), a third being present with a fire extinguisher. In commercial fuel stations a team member may proceed with the payment but will have to stay away from the vehicle.
- To access a refueling zone, it is recommended that the team members wear goggles and homologated clothing, and it is mandatory to wear long clothes.
- Engines must be switched off throughout the refueling operation and the crew must remain outside the vehicle during refueling, and it's forbidden to use mobile phones and radio communications while in the RZ.
- The fuel stations authorized will be indicated in the competitor Road Book with "FUEL STATION".

5.5 General Regulations for Service

- In the service area, only three team personnel may work on a competing vehicle. They will be identified by a distinctive armband supplied by the organizer. The crew may work freely during this period.
- Servicing the vehicle in the Transfer Zone (if any) is allowed only by the Crew using solely the equipment on board and with no external physical assistance except by crews with FIA groups vehicles still in the competition for the current leg may assist each other.
- Servicing the vehicle by the Service Team is restricted to be done only inside the Service Park, except for retired vehicles intending to re-start may be repaired outside of the Service Park. Obtaining a permission from the CoC is a MUST if the repair will take place inside a selective section.
- Servicing in a closed and/or private place is not authorized. If a car is serviced inside a closed tent, the Clerk of the Course must be informed and any official of the event must be allowed to enter the tent at any time.

5.6 Infractions of the Service and Refuelling rules - Penalties

All the infringements of the Service and Refuelling rules will be reported to the Stewards.

5.7 Environmental Mat

Inside the service park and the Parc Fermé competitors are obliged to lay a groundsheet (a minimum of 1 metre longer and wider than the vehicle in running order), under their cars to avoid the discharge of liquids on the soil (FIA CCRSR 51.2.2). Otherwise, it will be reported to the Stewards.

5.8 Garbage Bins

Inside the service park, the organiser will place garbage bins. Competitors must ensure their service location is clean before, during and after the rally, the Clerk of the Course will award a penalty of €150 to the competitor who has registered the car.

6 TWO-WAY RADIO

Not Applicable.

For rally related emergencies please call: **+9665 82 83 84 52**

7 FUEL/TYRES

7.1 Fuel

- All types of fuel must follow Appendix J Art. 252.9. (Art. 57 of the FIA CCRSR).
- Refuel stations\locations are marked in the Road Book, competitors are obliged to refuel in these stations only.
- Fuel available in these stations is Diesel, Gasoline 91 and 95 Octane.
- For more details refer to Articles 55, and 56, and 57 of the 2022 FIA CCRSR.

7.2 Tyres

- In accordance with Article 10 of the FIA CCRSR & Article 10 of Variation V2 of the FIA CCRSR.
- T1 FIA Priority drivers are allowed a maximum of 10 tires for all the Baja.

8 IMPORT OF VEHICLES AND SPARE PARTS

Parties wishing to import their car(s)/vehicle(s) to the Kingdom of Saudi Arabia should hold an ATA Carnet, which allows them to do so, in addition to a shipping manifest(s) that will include:

- The Vehicle(s) references;
- A detailed list of all the good and materials transported as well as their commercial value;
- Any other kind of light Vehicle onboard the Vehicle (bicycle, bike, quad, scooter, etc.).
- Others approved goods or materials.

It is imperative that the transported goods stay identical at all times throughout your stay within the Kingdom.

In all cases, the vehicle(s) original registration documents must always be available.

Nevertheless, Competing teams participating in the Baja, pledge and agree to pay in full the Saudi Automobile & Motorcycle Federation the custom taxes dues, in addition to other charges incurred in exchange for importing their racing vehicle(s), service vans and/or trucks, spare parts, tyres, and other various materials that are itemised and disclosed on the Trip Ticket(s) and/or shipping manifest(s), as a result of not re-exporting, consuming and/or selling them within the Saudi territories.

9 HOSPITALITY ARRANGEMENTS

9.1 Hospitality and Tourism

You may request accommodation assistance from the Organizer by contacting the secretariat of the Rally

Saudi Automobile and Motorcycle Federation
Ash Sharafiyah, Albaji 4627; Riyadh - Kingdom of Saudi Arabia
P.O. Box: 26095, Riyadh 12921 Tel.: +966 11 880 4614
E-mail: info@samf.gov.sa

For More details and discounts see appendix 7 bellow.

10 HOTEL/ ACCOMMODATION RESERVATION

10.1 Accommodation Reservations

10.1.1 Hotel Millennium Hail

Hail University Complex, Al-Khotta Rd.,

North Hail City Road Ha'il 55476

Telephone: +966 16 538 6111

Website: www.millenniumhotels.com

Services: Airport pickup service

10.1.2 Holiday Villa Hail

King Saud Road, Ha'il 55421

Telephone: +966 16 533 5555

Website: www.holidayvillahotels.com

Services: Airport pickup service

10.1.3 Golden Tulip Hail

Madina Road

Ha'il 81451

Telephone: +966 16 5419999

Website: www.goldentuliphail.com

Services: Airport pickup service

Estimated time to Baja H.Q. is 27 mins.

For More details and discounts see appendix 7 bellow.

11 SHAKEDOWN

Not applicable in the Saudi Baja 2022 - Hail.

12 START PROCEDURE

12.1 Saudi Baja Ceremonial Start Procedure & Order

In accordance with article 30 of 2022 FIA Cross-Country Baja Sporting Regulations

- The Ceremonial Start will take place according to Article 3 Programme of these regulations. It is mandatory for both Crew members to attend.
- No Timecard will be given before competitors go on the ramp.
- FIA Autos will go on the ramp first, followed by Bikes, then National Auto. All is ascending order.
- It is mandatory for all crew members to wear their FIA approved racing overalls, boots during the Ceremonial Start ramp. Crews not complying with this will be reported to the Stewards.
- All Competitors will start at one (1) minute interval. Then they will follow Marshal's instructions to TCO (QS), SS1A.
- A Timecard will be given at TC 0.

12.2 Leg 1 / Section 1– Start, Thursday November 10th, 2022, Procedure

- Cars will start from "TC 0" SS 1A Start (QS).

12.3 Leg 1 / Section 2 – Start, Friday November 11th, 2022, Procedure

- Cars will start from "TC 0B" Hail Service OUT.

12.4 Leg 2 / Section 3 – Start, Saturday November 12th, 2022, Procedure

- Cars will start from "TC 1C" Hail Service OUT.

13 FINISH PROCEDURE

- Competitors MUST enter the Finish Holding Area and follow marshal's instructions.
- The holding area will be secured. Access is limited to Crew members and Media representatives carrying the appropriate identification\accreditation.
- The Podium & Prize Giving will take place according to Article 3. It is mandatory for both Crew members to attend.
- The prize giving/trophies will be given in descending order according to classification.
- It is mandatory for all crew members to wear their racing overalls, boots during the Finish Podium. Crews not complying with this will be reported to the Stewards.

14 PR ACTIVITIES

Press Conference at the beginning and end of the event.

Before the Baja, and after the finish, two press conferences will be held for top Drivers chosen by the Organizer.

- The attendance of the summoned crews to the Rally Conferences will be compulsory except for reasons of force majeure accepted by the Stewards of the Event.

Media coverage:

1- Radio coverage - channels and frequencies:

- Live TV coverage on national T.V. of the Start, Finish, Prize Giving ceremonies in addition to round ups and flash news about the running of the Selective Sections in live mode from the Service Park.
- Daily summaries of the running of the event and interviews with drivers, organizers etc...
- Promotional spots will be broadcasted, one week prior the start of the Rally.
- Highlights about the day events will be broadcasted on the national

Reports, interviews and news about the Baja and its running, before, during and after the event, will be transmitted in live programs on many radios.

2- TV coverage – channels and times:

T.V. news, sports section.

Moreover, international TV stations will be covering and broadcasting news and highlights about the Baja.

15 MEDIA

15.1 Contact Details of the Media Services before and during the Rally

Title	Name	Mobile	Email
Public relations	Asma AL-HUMAID	+966 54 505 4222	aalhumaid@samf.gov.sa
Brand Manager	Faisal ALDAHMAH	+966 55 444 6447	faldahmash@samf.gov.sa

15.2 Media Accreditation Procedure

Media accreditation for Saudi Baja Hail 2022 shall only be attributed upon request which should reach the Organizers on November 5th, 2022 @ 17:00hrs at the latest through an email sent to info@samf.gov.sa.

The email must include:

- A formal accreditation request written on the publication's official letterhead, signed by the Director of the publication / agency.
- Name(s) and function of the representative(s) who will be covering the event.
- E-mail and a fax number.
- Credentials photocopies of the representative(s) who will be covering the event.

The right of the media accreditation approval is solely the Organizer's responsibility.

The misuse of the media accreditation in any form including the media card, the media tabard will result in confiscating the media accreditation and annulling it. The party concerned will also be reprimanded as a first notice.

The Organizing Committee reserves its right to issue and/or to withdraw any accreditation without prior notice.

A fully equipped and bi-lingually (English and Arabic) staffed media centre will be located at the Rally HQ and operational from Tuesday, November 8th, and as per below schedule.

Opening Hours

Date	Time
Tuesday, November 8 th	11:00 – 17:00hrs
Wednesday, November 9 th	09:00 – 22:00hrs
Thursday, November 10 th	08:00 – 22:00hrs
Friday, November 11 th	08:00 – 22:00hrs
Saturday, November 12 th	08:00 – 20:00hrs

15.3 Media Safety

We do acknowledge that the Media play an important role in our events and that each member must be permitted to carry out his or her duty in the best possible surroundings. However, they are not exempted from having to respect safety regulations. In general, this should not interfere with their ability to perform their duties. Nevertheless, safety will always take priority. Such is the open nature of the Baja; we request that our media colleagues pay special attention to our marshals' advice and orders this year and take extra safety precautions themselves. Please enjoy a safe event.

16 PASSES AND PLATES

16.1 Passes



ID Card
- 1 for each

16.2 Parking Spots for Officials Cars



16.3 Plates / Stickers for Officials cars

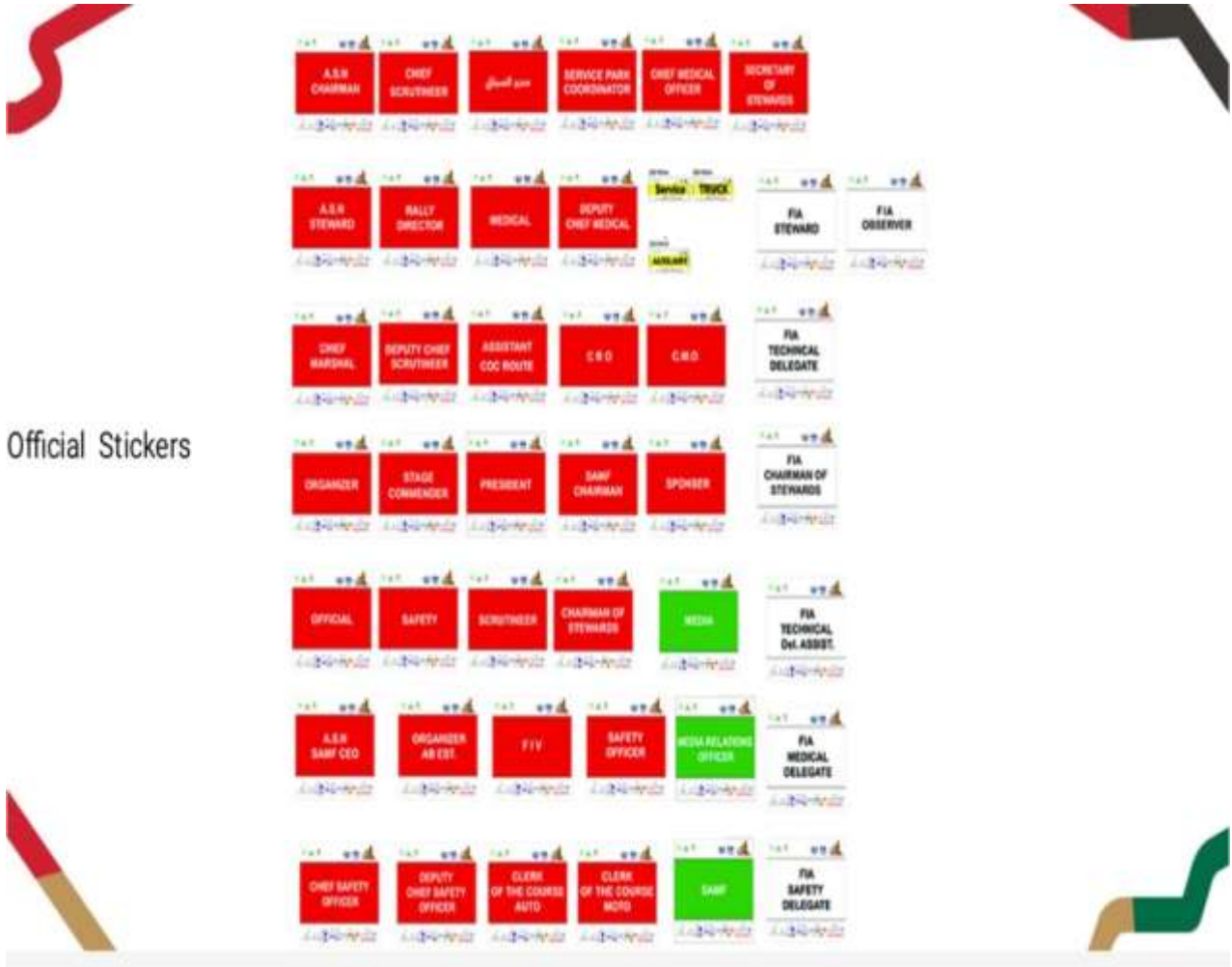

Official Stickers

17 MEDICAL AND SAFETY SERVICES

17.1 Emergency Telephone Numbers

● Police assistance	999 / 911
● Fire emergency response	998
● Car accidents	993
● Public ambulance services	997
● Natural disasters	966
● Coast guard	994
● General emergency	112

17.2 List of some Hospitals in the Area, Addresses & Telephone Numbers:

Name of Hospital	Address	Phone #
Hail General Hospital Samah	Hail, 55428	+966 16 558 2115
King Khalid Hospital	King Abdulaziz road, Hail	+966 16 532 8888
King Salman Specialist Hospital	Al Masyaf, Hail, 55471	+966 16 236 2222
Salamat Hospital	Jeddah Rd. Hail, 55427	+966 16 536 6666

17.3 List of some pharmacies in the Area, Addresses & Telephone Numbers:

Name of Pharmacy	Address	Phone #
Almass Pharmacy	Al Samra, 4195, Hail 55425	+966 16 531 1010
Al-Nahdi Pharmacy	King Abdulaziz road	+966 92 002 4673
Aljamaen Med. pharmacy	Samah, Hail 554285	+966 50 516 2377
Salamat Pharmacy	Al Matar	+966 16 535 6600
Misk Pharmacy	Aja, 7498, Hail 55471	+966 16 531 7620
Alzahra Pharmacy	Al Zahra', Hail 55481	+966 55 386 1700

18 USEFUL FACTS AND SERVICES

18.1 Climate

In general, high temperatures during the day and low temperatures at night mark the climate of Saudi Arabia. The country follows the pattern of the desert climate, with the exception of the southwest, which features a semi-arid climate.

Hail lies on 1000 m above sea level. The climate here is “desert”, and virtually there is no rainfall during the year. The average temperature in Hail is 20.9°C.

18.2 Time zone

Time zone in Saudi Arabia (GMT+3)

18.3 Currency

The Saudi Riyal (Arabic: riyāl sa‘ūdī); is the currency of Saudi Arabia. It is abbreviated as SAR for Saudi Arabian Riyal. It is subdivided into 100 halalas.

18.4 Hire car companies

■ BUDGET	King Abdulaziz Rd, Al Matar, Hail	+966 12 962 7070
■ AVIS	Hail International Airport	+966 9200 28281
■ THEEB	Hail International Airport	+966 9200 00572

18.5 Airports and airline companies

Passengers bound for Hail have to stop first in either Riyadh or Jeddah first since nonstop flights are not available.

Ha'il Regional Airport (IATA: HAS) is an airport serving Hail (spelled in arabic Ha'il), the capital of the Ha'il Province in the Kingdom of Saudi Arabia.

Regular scheduled passenger service is provided by Air Arabia, Flydubai, Flynas, Nesma Airlines, Nile Air, and Saudia.

18.6 Copy service

Jarir Bookstore North Ring Road, Al-Zahra, Hail 55481 +966 92 000 0089

18.7 Mobile phone (rental and service)

Are not available to hire

There are pre-paid SIM cards available for mobile phones (available at STC, Zain, and Mobily stores or authorized dealers)

18.8 Security companies

Not Available.

18.9 Taxis

Careem and Uber services are widely used in all over the Kingdom of Saudi Arabia. Their apps are on all kinds of mobile operating systems.

18.10 Speed Limits in Saudi Arabia

The speed limit signs on the public road are in KM. Some of them are in Arabic and therefore a table below is attached that shows the speed equivalent Arabic/English.

Take note that speed limits are other infringements such as mobile phone use while driving are strictly enforced and with high penalties. There are numerous movable speed monitoring cameras on the road. It is highly advisable to stick with posted speed limits.

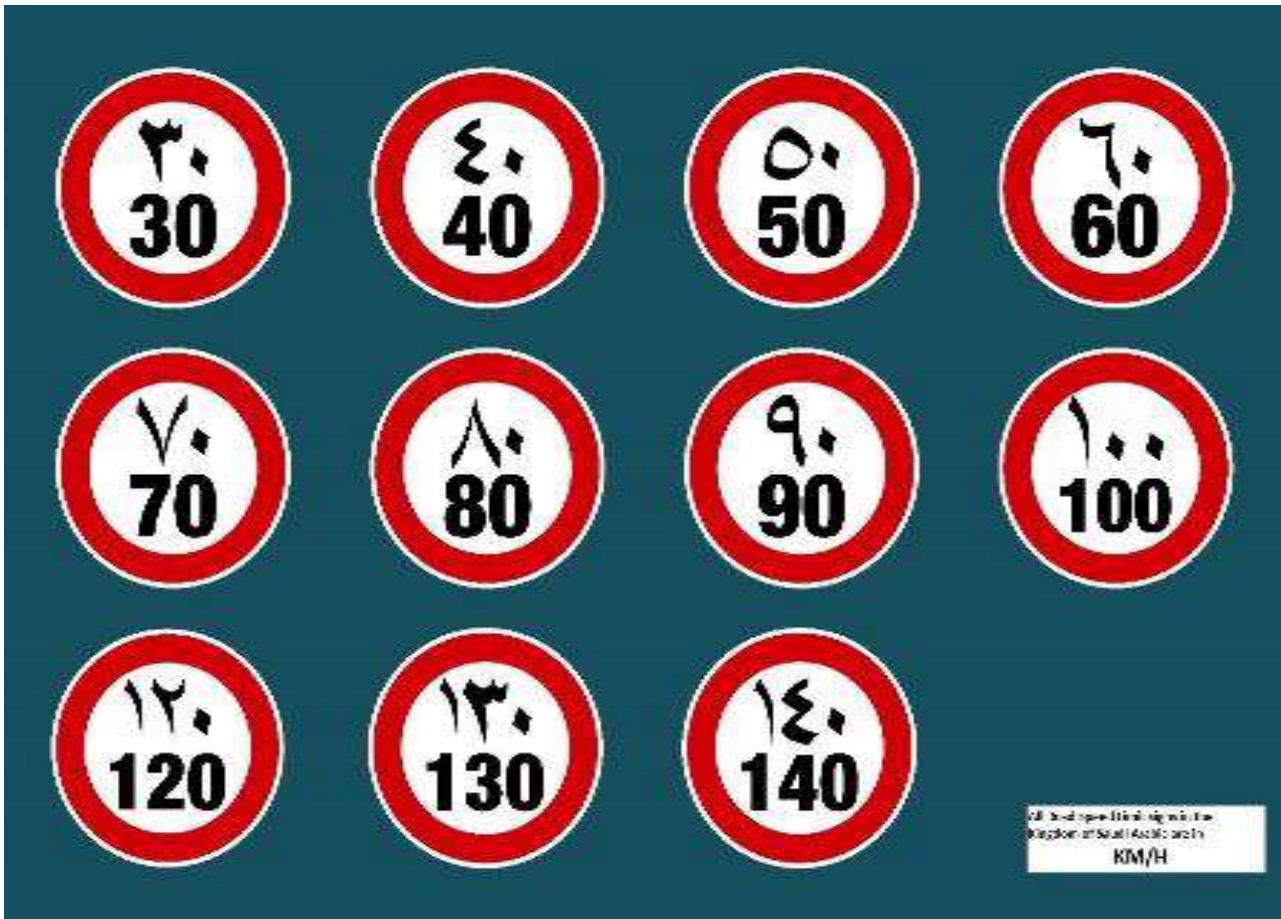

19 APPENDIX 1 – ITINERARIES

SAUDI BAJA - HAIL 2022 (AUTO)							
LEG 1 Thursday, Nov 10th, 2022							
TC SS	Location	SS km	Liaison km	Total km	Max. Time	Target Time	1 st Car Due
0	Start OS HAIL						15:45
DSS 1A	SS1A HAIL	3.91	0.10	0.10	0.15	0:05	15:50
ASS 1A	Finish SS1A HAIL			4.01		Expected time of arrival	(16:10)
	Stop OS HAIL		0.17	4.18			
0A	HAIL Service IN *		24.49	28.67		0:45	16:55
HAIL Service A							
LEG 1 / Section 1 TOTAL		3.91	24.76	28.67			
		13.64%	86.36%	100.00%			
* Early Arrival Permitted							
Sunrise 6:28 Sunset 17:25							
LEG 1 Friday, Nov 11th, 2022							
TC SS	Location	SS km	Liaison km	Total km	Max. Time	Target Time	1 st Car Due
0B	HAIL Service OUT						7:00
1	Start S.S. JUBBAH		108.02	108.02		1:50	8:50
DSS 1B	SS1B JUBBAH	101.62	0.10	108.12	2:45	0:05	8:55
ASS 1B	Finish SS1B JUBBAH			209.64		Expected time of arrival	(10:35)
RZ 1 Refueling Zone T3 & T4 Only							
Neutralization Zone (20 minutes)						0:20	
DSS 1C	SS1C JUBBAH	0.71		209.64	3:15		(10:55)
ASS 1C	Finish SS1C JUBBAH			327.64		Expected time of arrival	(12:05)
	Stop S.S. JUBBAH		0.36	338.00			
1A	Technical Zone IN *		49.87			1:30	14:35
1B	Technical Zone OUT / HAIL Service IN			387.87		0:15	14:50
HAIL Service B							
LEG 1 / Section 2 TOTAL		229.02	158.36	387.87			
		59.17%	40.83%	100.00%			
* Early Arrival Permitted							
Sunrise 6:28 Sunset 17:25							
LEG 2 Saturday, Nov 12th, 2022							
TC SS	Location	SS km	Liaison km	Total km	Max. Time	Target Time	1 st Car Due
1C	HAIL Service OUT - Start LEG 2						7:00
2	Start S.S. FARHANIYAH		57.15	57.15		1:20	8:20
DSS 2A	SS2A FARHANIYAH	84.04	0.10	57.25	2:20	0:05	8:25
ASS 2A	Finish SS2A FARHANIYAH			141.29		Expected time of arrival	(09:45)
RZ 2 Refueling Zone T3 & T4 Only							
Neutralization Zone (20 minutes)						0:20	
DSS 2B	SS2B FARHANIYAH	1.09		141.29	2:40		(10:05)
ASS 2B	Finish SS2B FARHANIYAH			240.67		Expected time of arrival	(11:45)
	Stop S.S. FARHANIYAH		0.58	241.25			
2A	HAIL Finish Holding IN *		117.85	359.10		2:00	13:45
Prize Giving Ceremony **							19:30
LEG 2 / Section 3 TOTAL		183.42	175.68	359.10			
		51.88%	48.92%	100.00%			
* Early Arrival Permitted							
** Follow Marshal's Instructions							
V.14							
Rally Totals		SS	Liaison	LEG Total	%		
LEG 1 / Section 1		3.91	24.76	28.67	13.64%		
LEG 1 / Section 2		229.52	158.35	387.87	59.17%		
LEG 2 / Section 3		183.42	175.68	359.10	51.08%		
Total		416.85	358.79	775.64	53.74%		

20 APPENDIX 2 – MAPS



21 APPENDIX 3 – ROAD BOOKS

21.1 From Hail International Airport to Millennium Hotel / Rally HQ

- On Google Maps just put “Millennium Hotel Hail”
- GPS waypoints: 27°39'10.4"N 41°43'26.8"E
- Millennium Hotel/ Rally HQ Google maps link: <https://g.page/Millenniumhail?share>.

21.2 From Millennium Hotel / Rally HQ to Hail International Airport



- On Google Maps just put “Hail International Airport”
- GPS waypoints: 27°26'17.9"N 41°41'24.7"E
- Airport Google maps link: <https://goo.gl/maps/ehckvx8HJrz6GidC6>.

21.3 ERTF LINK



- https://www.ertf.com/support.asp?lg=_uk

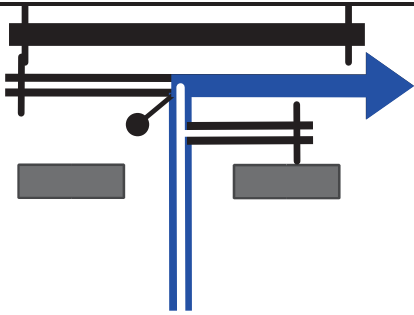
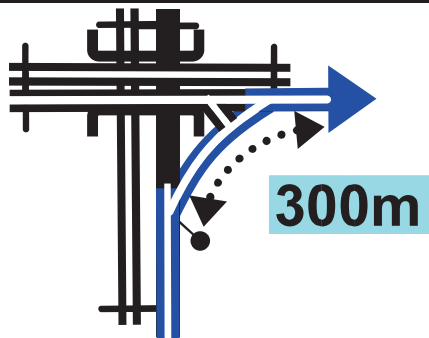
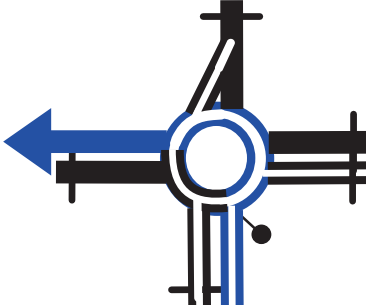
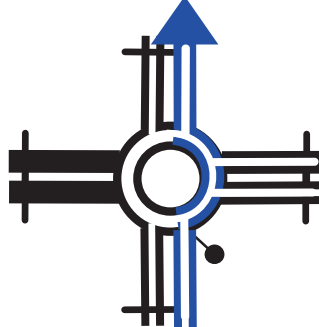
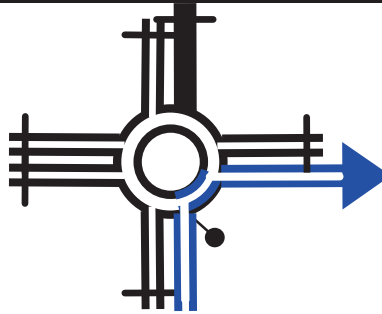

21.4 Road Books

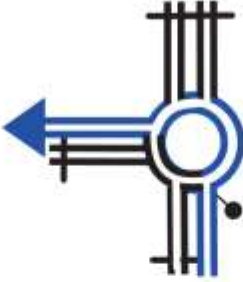
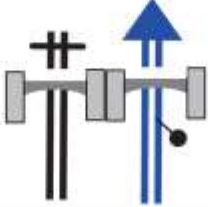
- Service Park to Ceremonial Start Location
- SS1A Finish to Service Park

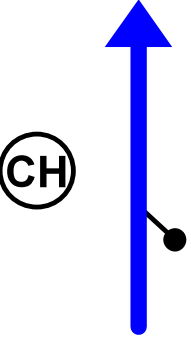

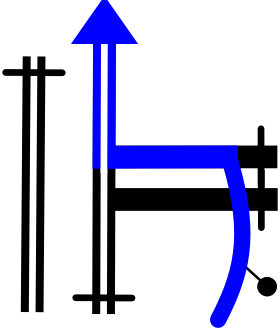
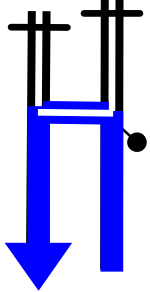
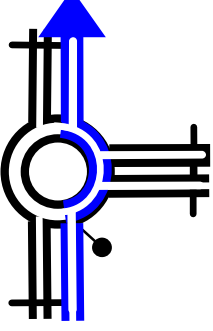
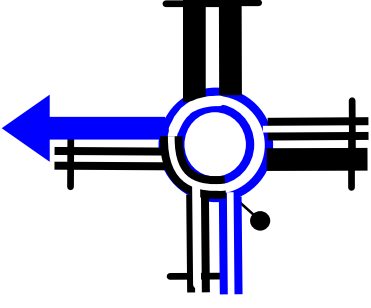
1	BAJA HAIL / ETAPE 1A / LIAISON PODIUM	Km : 25.89
0.00		
0.00		
0.48		
0.48		
8.44		
7.96		
13.64		
5.20		
16.57		 ASHAR
2.93		

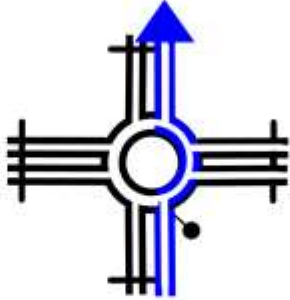
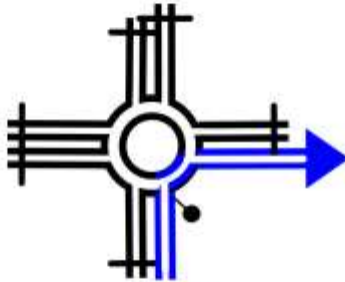
2	BAJA HAIL / ETAPE 1A / LIAISON A	Km : 25.89
18.07		
1.50	<div data-bbox="754 636 903 696" style="border: 1px solid black; padding: 2px; text-align: center;">PODIUM</div> 	②
20.41 2.34 ↓ E		

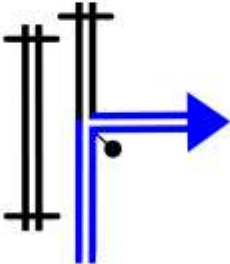
1	BAJA HAIL / ETAPE 1A / LIAISON B		Km : 24.49
<p>0.00</p> <p>0.00</p>		 <p>CH LIAISON</p>	
<p>2.23</p> <p>2.23</p>			
<p>2.58</p> <p>0.35</p>		<p>U-TURN</p>	
<p>3.92</p> <p>1.34</p>			
<p>5.47</p> <p>1.55</p>			

2	BAJA HAIL / ETAPE 1A / LIAISON B	Km : 24.49
<p data-bbox="229 338 448 434">8.46</p> <p data-bbox="180 506 347 582">2.99</p>		
<p data-bbox="201 669 469 766">13.61</p> <p data-bbox="180 837 347 913">5.15</p>		
<p data-bbox="196 1001 480 1097">20.76</p> <p data-bbox="180 1169 347 1245">7.15</p>		
<p data-bbox="196 1332 480 1429">23.16</p> <p data-bbox="180 1500 347 1576">2.40</p>	<p data-bbox="544 1323 743 1487">UNIVERSITY</p> 	
<p data-bbox="196 1664 480 1760">24.35</p> <p data-bbox="180 1832 347 1908">1.19 ↓</p>		

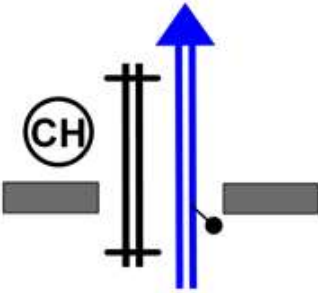
Next 0.14

3	BAJA HAIL / ETAPE 1A / LIAISON B	Km : 24.49
<div style="background-color: #90EE90; padding: 10px; text-align: center; font-size: 2em; font-weight: bold;">24.49</div> <div style="background-color: #90EE90; padding: 5px; text-align: center; font-size: 1.5em; font-weight: bold;">0.14</div>		 CH LIAISON 10

22 APPENDIX 4 – DRAWINGS AND LAYOUTS

22.1 Scrutineering Venue Layout



SCRUTINEERING LAYOUT

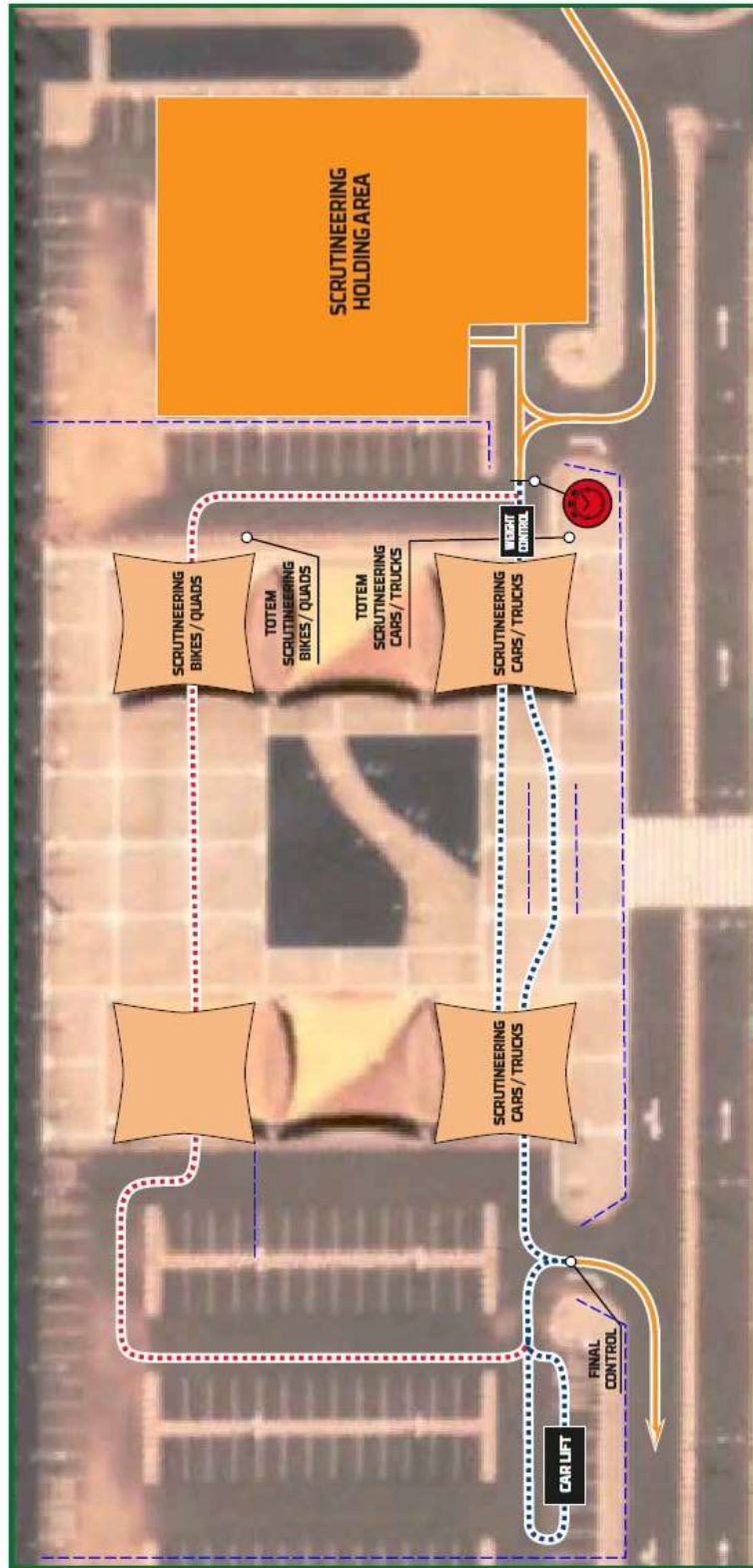

الاتحاد السعودي للسيارات والدراجات النارية
Saudi Automobile & Motorcycle Federation



22.2 Parc Ferme Layout



PARC FERME LAYOUT

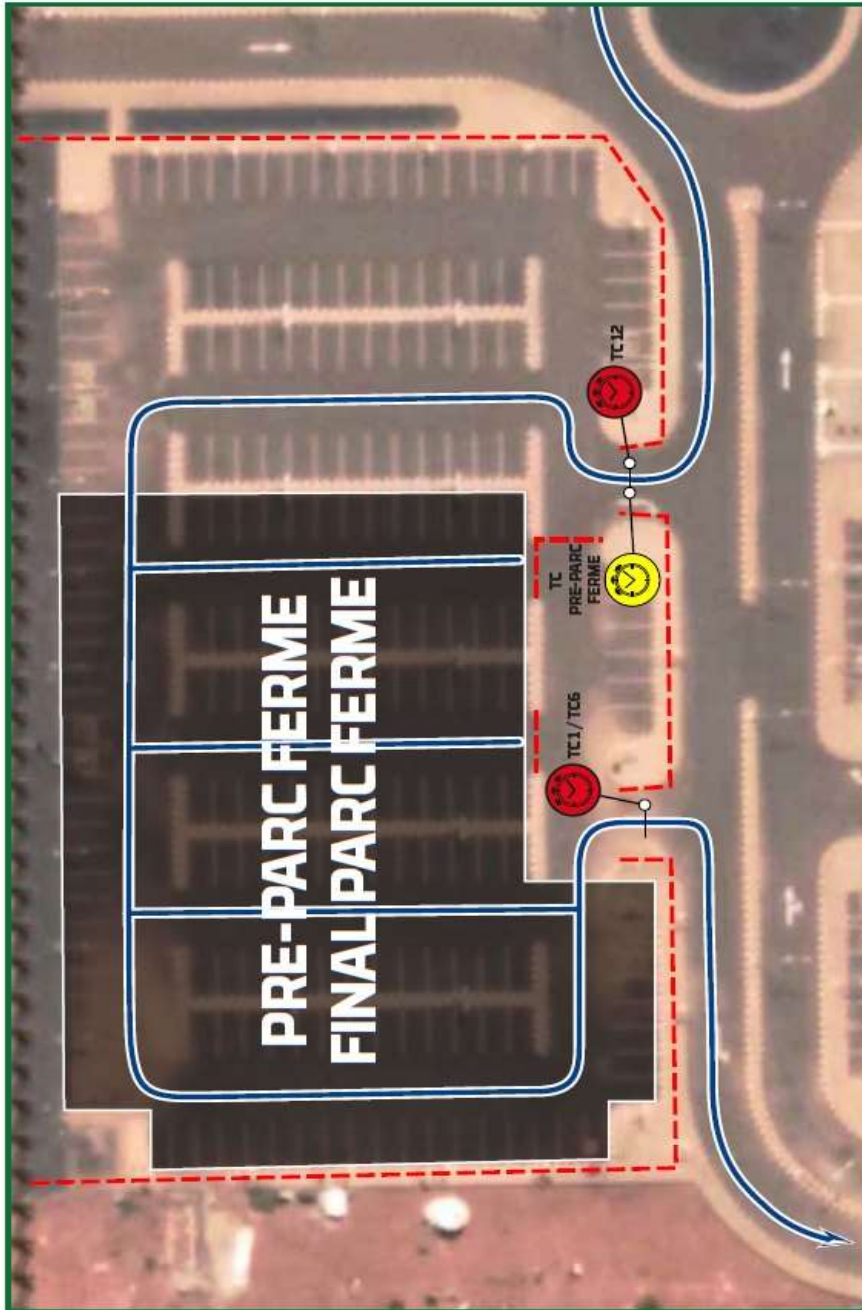

الاتحاد السعودي للسيارات والدراجات النارية
Saudi Automobile & Motorcycle Federation



22.3 Rally HQ Layout



الاتحاد السعودي للسيارات والدراجات النارية
 Saudi Automobile & Motorcycle Federation

22.4 Service Park Layout



SERVICE PARK LAYOUT



الاتحاد السعودي للسيارات والدراجات النارية
Saudi Automobile & Motorcycle Federation



23 APPENDIX 5 – SUMMARY OF PENALTIES

Infringement	Article No.		By Stewards		By CoC				
			Stewards Decision	Disqualification	Start Refused	Section Penalty	LEG Penalty	Time Penalty	Financial Penalty (€)
Competitor not reporting accidents	SR	5.1.7	X						
Reporting outside the schedule for Admin Checks (max 15min)	SR	9.2	X						15/min
Reporting outside the schedule for Scrutineering (max 15min)	SR	10.1							15/min
Tampering, manipulating or interfering with the Tracking device.	SR	10.5	Max Discq						
Failing to comply with ADR requirements	SR	10.5.5	X						
Refusal to equip the vehicle with the organizer OBSC	SR	10.5.6	X		X				
No windscreen, and not wearing Goggles or a Full Helmet with visor at start of LEG	SR	10.9			X				
Not attending the compulsory drivers Briefing	SR	11.1							150
Lateness up to 30 minutes at Pre start Hold	SR	11.2							150
More than 30 minutes late at Pre start Hold	SR	11.2	X						
Exceeding Speed Control Zone Limit	SR	11.13.3					X		X
Not Communicating withdrawal from Baja	SR	11.13.4							150
Exceeding Maximum permitted lateness at TC	SR	11.13.5				X		1 h/TC	
Service teams and accompanying persons	SR	11.10.3							250
Environmental Mat	SR	11.10.8	X						150
Garbage Bins	SR	11.10.9							150
Infringements of Service Park/Refuel rules	SR	11.10.14	X						
Fake SOS			X		X				
Less Than 51% way points achieved in Leg 2			X						
GPS/NAV not in operational	CCRSR	12.3.2	X					15 m	
Loss of Timecard	CCRSR	14.3.4						10 m	
Absence or wrongly affixing of compulsory / optional advertising: 1 st offence (percent of entry fees)	CCRSR	20.3 V2							10%
Absence or wrongly affixing of compulsory / optional advertising: any repeated offences (percent of entry fees)									100%
Name of driver & co-driver not in compliance (percent of entry fees)	CCRSR	21.3							10%
Wrist Band/Bracelet lost (percent of entry fees)	CCRSR	21.3							10%
Vehicle not passing Scrutineering			X						
Absence of marks & seals	CCRSR	24.1.3	X						
Maximum lateness at a start	CCRSR	31.2			X	X	X		

Infringement	Article No.		By Stewards		By CoC				
			Stewards Decision	Disqualification	Start Refused	Section Penalty	LEGG Penalty	Time Penalty	Financial Penalty (€)
If Crews did not check in in the correct sequence of controls and in the direction of the event route:	CCRSR	35.4.2						10 m	
- 1 st infringement: 10 minutes,								1 h	
- 2 nd infringement: 1 hour,						X			
- 3 rd infringement: disqualification									
Exceeding Control Zone speed	CCRSR	37.2.6						10sec	
- Between 1 and 5 kph (sec/pulse)								1 m	50
- Between 6 and 15 kph (min/pulse)								2 m	100
- Between 16 and 40 kph (min/pulse)								5 m	300
- More than 40 kph 1 st pulse								10 m	500
- More than 40 kph 2 nd pulse								15 m	700
- More than 40 kph 3 rd pulse									
- Any further pulses over 40kph			X						
Diff. between check-in time and target check-in time	CCRSR	38.2.10						10sec	
- Late arrival (per minute or fraction)								1 m	
- Early arrival (per minute or fraction)									
Start delay by crew at TC (per minute or fraction)	CCRSR	42.4.1						1 m	
Refusing to start SS at the allocated time	CCRSR	42.4.2						1 h	
Fails start within 20 seconds of the starting signal.	CCRSR	42.4.3						2 m	
Vehicle did not start SS	CCRSR	42.4.4				X			
False start made before the signal has been given	CCRSR	42.5						1 m	
- 1 st offence								3 m	
- 2 nd offence								10 m	
- 3 rd offence									
- Further offences			X						
Missing more than 40% of the total # of waypoints during a leg	CCRSR	43.1.4				X	X		
Non-validation of a WPE waypoint (for each waypoint)	CCRSR	43.1.6						15 m	
Stopping between the yellow warning signs and the STOP signs is forbidden	CCRSR	44.1.2						15 m	
A competitor who does not stop at the stop point to have his times entered	CCRSR	44.2.3						1 h	
A vehicle towed or pushed through a time control	CCRSR	44.2.4							
Competitor not assisting in case of an accident	CCRSR	48.4.5	X						
Exceeding max. time allowed for SS (+missing WP + TC)	CCRSR	49.1 V2				X			

Infringement	Article No.		By Stewards		By CoC				
			Stewards Decision	Disqualification	Start Refused	Section Penalty	LEG Penalty	Time Penalty	Financial Penalty (€)
Exceeding max. permitted lateness at TC's or not checking in one or more TC (penalty/TC)	CCRSR	49.2 V2							
- @ Start TC of each LEG					X	X	X	1 h	
- @ The final TC of LEG 1								1 h	
- @ The final TC of LEG 2				X					
Reporting late for the start of a Leg if exceeding 30 min							1 h		
Any crew which doesn't follow the refuelling regulations, in addition to the neutralization time stipulated in the SR will receive time penalty of	CCRSR	56.1.3						15 m	
Parc Fermé: delay beyond the original start time (per minute or fraction, max 30 min)	CCRSR	58.7.3						1 m	
The itinerary and the road direction diagrams in the road book must be followed.			X						
Any crew refusing to start a selective section at the time and in the position allocated to it			X						

- The Stewards may impose further penalties not mentioned above.
- The Above table contains Summary of Penalties from the 2022 FIA CCRSR and this SR, In Case Of Any Discrepancy, between the penalties in the Latest Version of the 2022 FIS CCRSR and the Above Penalty Summary Table, the FIA CCRSR and its appendices will be binding.

24 APPENDIX 6 – DIGITAL OFFICIAL NOTICE BOARD -
SPORTITY



The banner features a purple and pink background with a white rounded rectangle in the center containing the password. It includes the Sportity logo, a QR code, and app store links.

 **Sportity**

For direct event information please download the Sportity app and insert this password:

HAIL22FIA

Sportity app is available in

www.sportity.com

Ladies and Gentlemen

In preparation to Hail International Toyota Rally 2022 part of the Saudi Toyota Championship, the Saudi Automobile & Motorcycle Federation is happy to provide accommodation and vehicle transportation service offerings during your stay in the city of Hail.

Service	Details	Price (Taxes included)	Discount code
 Morni Transportation Service	Car shipping and maintenance application	Discount 20%	S A M F
 Holiday Villa Hotel	Standard Single Room (Breakfast included)	320 SAR	S A M F For reservations : 0548875220
	Deluxe Double Room (Breakfast included)	380 SAR	
 Suknai Hotel	Deluxe Double Room (Breakfast included)	397 SAR	S A M F For reservations : 0535118000



الأخوات والأخوان الكرام

حرصاً من الاتحاد السعودي للسيارات والدراجات النارية على اقامتكم اقامة مميزة في مدينة حائل للمشاركة في بطولة السعودية تويوتا 2022 لسباق رالي حائل تويوتا الدولي تم توفير الخصومات في الجهات ادناه :

كود الخصم	السعر (شامل الضريبة)	التفاصيل	الخدمة	
SAMF	خصم 20%	تطبيق لشحن وصيانة السيارات	مرني خدمة النقل	
SAMF للحجز : 0548875220	320 ريال	غرفة ستاندرد مفردة (شامل الإفطار)	فندق هوليداي فيلا	
	380 ريال	غرفة ديلوكس مزدوجة (شامل الإفطار)		
SAMF للحجز : 0535118000	397 ريال	غرفة ديلوكس مزدوجة (شامل الإفطار)	فندق سكناي رويال	

